



## RWR Rewind Unit

RWR is an automatic rewinder for self adhesive labels in roll. It mainly consists of a basic plate (pos.1) which is used as printer base.

Rewinder assembly (pos. 2): it rewinds the roll and is equipped with a spindle adjustable from 40 to 110 mm. The adjustment is made by unscrewing the knob (pos. 2.1) and by moving the adjusting disc (pos. 2.2).

Control assembly (pos. 3): it is on the back of the machine and consists of ON/OFF switch with protection fuses (pos. 3.1), switch for clockwise/anticlockwise rewinding (pos. 3.2) and potentiometer to adjust the speed range (pos. 3.3).

Tension assembly (pos. 4): it adjusts automatically the speed according to the printer speed, within the range of speeds adjusted by the potentiometer. When the paper is finished, a sound signal is activated and the motor is stopped.

To which this statement refers is COMPLIANT with the provisions of the Laws dictated by the 20006/42/CE.

To which this statement refers is COMPLIANT with the provisions of the Laws dictated by the 20006/95/EC (BT); 2004/108/CE (EMC); 2011/65/CE (RoHS); 2002/96/CE (WEEE).

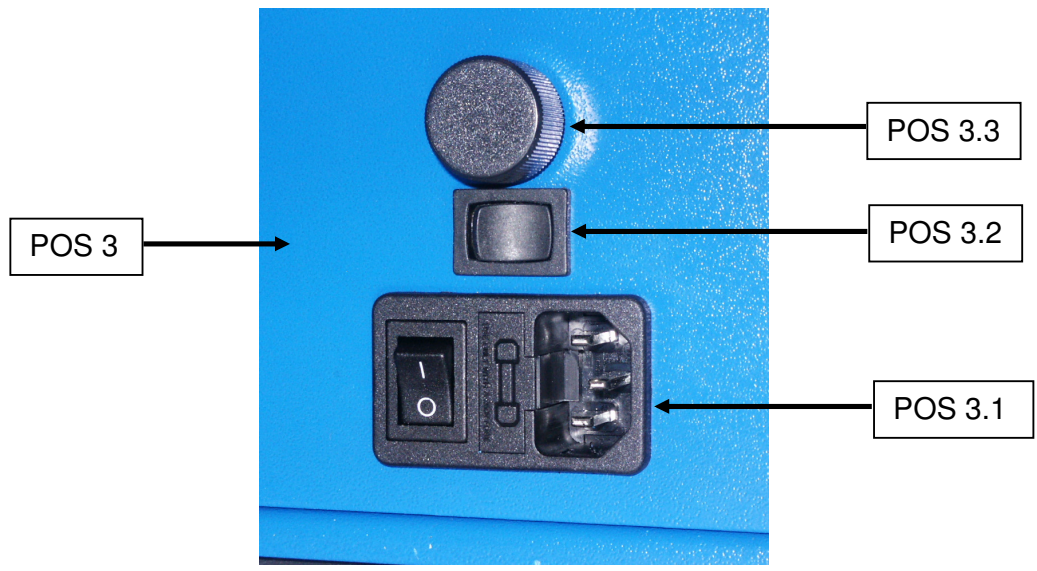
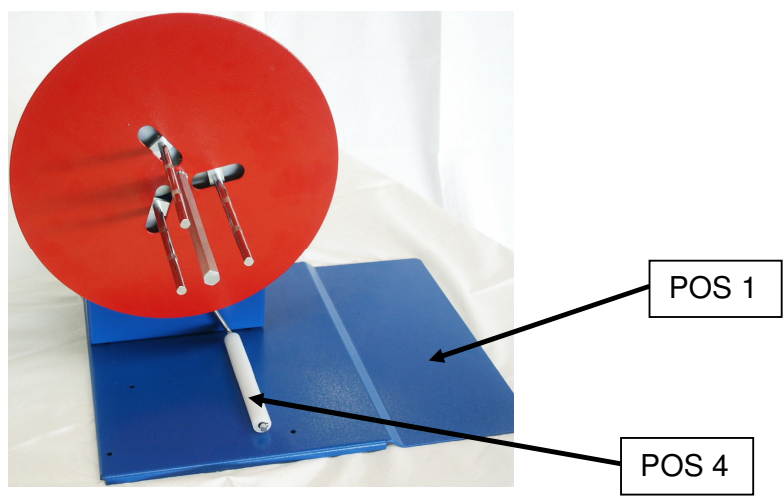
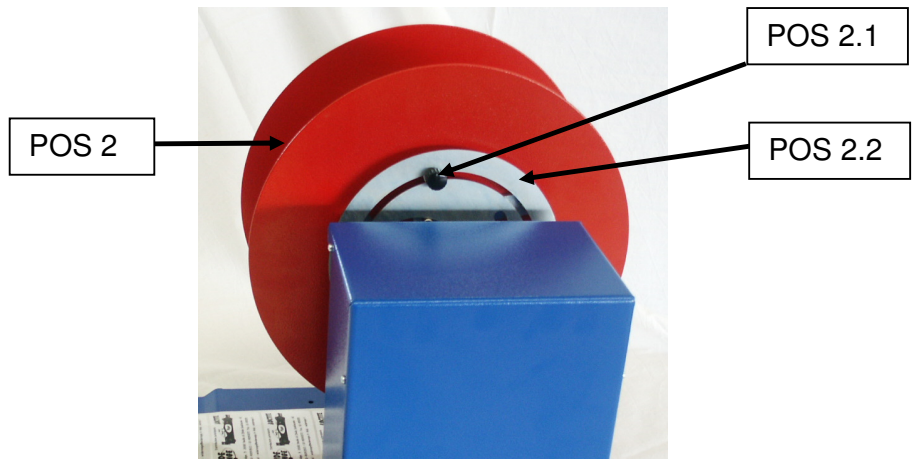

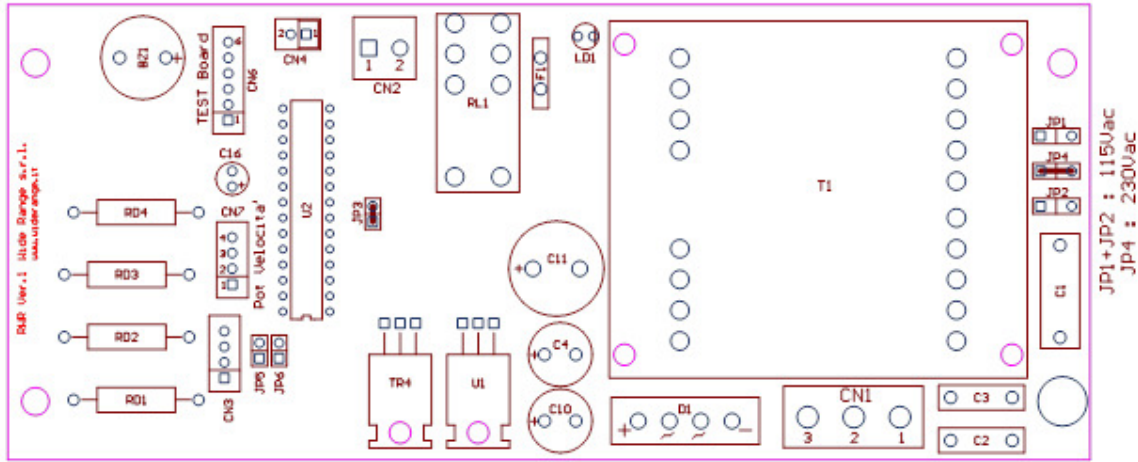

Comp RWR Ver1

